

INPUT / OUTPUT MINI MODULES



APPLICATION

The Addressable Control and Monitor mini modules are the latest technology for a loop powered module. Installed on the same loop with other devices such as detectors and manual call points, without the need for any external power supply. It can be supplied in five versions:

- 50100 Single input mini module
- 50010 Single output mini module
- 50002 Dual output (Form C) mini module
- 50110 Single input/output mini module
- 50102 Single input/dual output (Form C) mini module

The vast combination of configuration makes the module to meet the demand of wide range of application such as Lift Control, AHU handling, Sprinkler Systems and Fire Fighting Integration, Door Controls or any other application where hard wired monitoring or control are required.

APPROVALS & COMPLIANCE WITH STANDARDS

The entire VELOX range confirms to BS5839 part 1&4, EN54 Standards. The Mini addressable modules are approved to EN-17 and EN-18. This only means enhanced reliability and precision performance.

Features

- Complies to EN54-18 standards
- Connected and powered from the same loop
- Soft Addressing
- Safe Addressing
- Short Circuit Isolators complying to EN54-17
- Up to 240 devices per loop
- Twin Bi-color LED driven from the control panel

PHYSICAL CONSTRUCTION & ASSEMBLY

The mini modules is constructed from high impact ABS designed to be fitted in any standard electrical box or in a weather box to enhance the IP rating. All the wires can be terminated on the screw channel, which is marked with numbers; depending on part number a full diagram is provided to insure proper installation.

The unit is supplied with Bi-Color LED that provides status and alarm (Green / Red) indications and can be connected directly on the loop.

Up to 240 devices can be connected and powered from the loop, each device shall have inbuilt isolator allowing the unit to be isolated in case of short circuit on the line, without affecting the other device on the loop.

TECHNOLOGY

The mini modules embedded with the latest ATEIS digital protocol technology. The patented communication protocol has a unique design of Variable Time Communication "VTC". This new technology allows the data packets to be transmitted on the Fire Detection Loop for a long distances and does not get affected with the Cable Characteristics. This technology clubbed with the DIN Rail configuration shall help a healthy communication at the worst site installation conditions or even during the severe fire conditions and especially in the industrial application.

The Soft Addressing, Safe Addressing feature allows the commissioning team to set new address not necessary in the same sequence, this excellent feature shall allow the addressing to match site conditions or even allows the user to add more detectors to the loop at later stage without the need to change the addresses of all the devices.

Each device is supplied with in-built short circuit isolator complying to EN54-17, in case of a single fault; no device shall be lost on the loop. This shall only provide higher reliability to the performance as well easy of installation to comply with the latest standards and regulations.

Two types of output modules provided. The supervised output can drive up to 2Amp of 30VDC or AC of a resistive type load, hence Open, Short and Earth conditions are fully monitored. This can be used to drive any conventional sounders, bells, Relays or any other Resistive Load type.

The unsupervised relay output is of SPDT relay type; each module shall be supplied with two double throw relays of "C" form which drives the same type of load.

The input modules shall supervise any input for Alarm, Short, Open and Earth conditions and can be used for the different types of monitoring such as, Sprinkler Systems, Fire Pumps or any other inputs from key switches, doors, alarms or fans.

The unit is equipped with twin Bi-color LED, which can give indications for Normal Operation "Green" or Alarm "Red" for every channel. Each Input or output module shall occupy one address, if combined in one unit shall occupy two addresses.

If the VPU is used to address mini module, then first addressed shall be assigned to the Input and the output shall take one address higher. If the Soft addressing is used by the control panel, then Fire Panel shall assign all the addresses automatically.

ARCHITECTURAL & ENGINEERING SPECIFICATIONS

The unit must be the ATEIS module addressable intelligent control / monitor module. Up to 240 devices can be connected on the same detector loop based on the load factor. The intelligence addressable module shall be equipped with the latest state of the art microprocessor which shall control the communication and monitoring of the software and hardware of the unit. The unit shall communicate over state of the art Variable Time Communication "VTC" digital protocol from ATEIS which shall allow the safe and fast communication between the unit and the Fire Alarm Control Panel.

The Module shall be equipped with twin Bi-color LED in both Red "Alarm" and Green "Normal / Presence" indications, one per channel. These LED's can be controlled fully from the Fire Alarm Control Panel. Each Intelligent Module shall be as well equipped with in-built isolator allowing the device to isolate itself from either side if a short may happen on the detector loop line. This feature must be fully complying with EN54-17 to allow no device lost in case of a single short on the loop.

The Input modules shall fully monitor the third party connected to it for Open, Short, Earth, Alarm and Normal Condition. The end of line resistor of 27Kohm shall monitor the line for Open, earth or short, where as a series of 10Kohm alarm resistor can provide and alarm condition to the line. This feature allows monitoring both Alarm / Condition with one device and with one address.

The output module shall be either of supervised or unsupervised. Both shall drive 2Amp of 30 Volt DC/AC resistive loads. The supervised output can drive conventional Sounders, Bells, Relays or any other third party devices, where as the un-supervised is equipped with two SPDT "double Throw" C format relays that can drive 2Amp at 30Volt AC/DC resistive load.

By using the VPU100 programmer can assign address to the unit, this safe addressing feature allows the device to have address after the Soft Addressing to match site requirements or special addressing requirements. The unit comes in mini enclosure format suitable to be mounted in any standard electrical box to suit environment conditions.

GENERAL OVERVIEW - 50100 INPUT MINI-MODULE

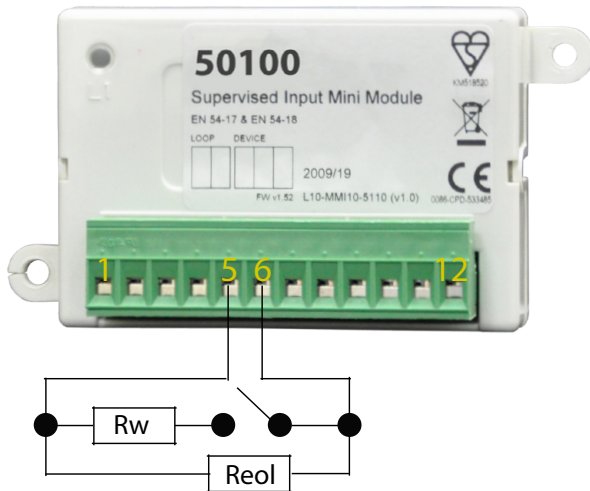

Terminal		Description
1	Loop line IN (+)	Loop positive input
2	Loop line OUT (+)	Loop positive output
3	Loop line IN (-)	Loop negative input
4	Loop line OUT (-)	Loop negative output
5	Input (+)	Supervised input (+)
6	Input (-)	Supervised input (-)
7	Not used	
8	Not used	
9	Not used	
10	Not used	
11	Not used	
12	Not used	

The 50100 single channel supervised input mini-module provides monitoring of normally open contact fire alarm and supervisory devices.

End of line resistor (Reol):27 Kohm. - Alarm resistor (Rw):10 Kohm.

GENERAL OVERVIEW - 500105 OUTPUT SUPERVISED MINI-MODULE

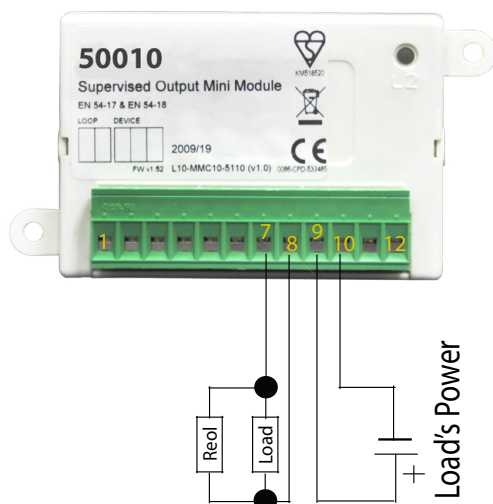

Terminal		Description
1	Loop line IN (+)	Loop positive input
2	Loop line OUT (+)	Loop positive output
3	Loop line IN (-)	Loop negative input
4	Loop line OUT (-)	Loop negative output
5	Not used	
6	Not used	
7	Load (+)	Supervised output (+)
8	Load (-)	Supervised output (-)
9	Load power (+)	Load's power supply (+)
10	Load power (-)	Load's power supply (-)
11	Not used	
12	Not used	

The 50010 single channel supervised output mini-module provides control, by closing contacts, of auxiliary devices such as fire shutters.

End of line resistor (Reol):27 Kohm.

GENERAL OVERVIEW - 50002 OUTPUT FREE CONTACTS MODULE

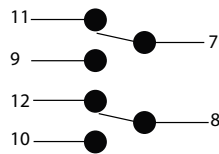
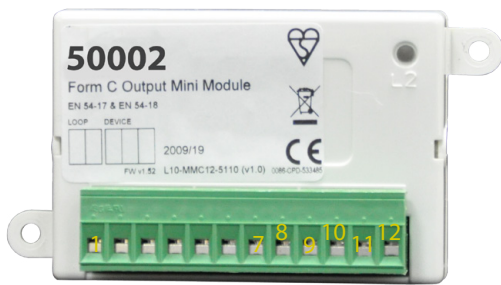

Terminal	Description
1	Loop line IN (+)
2	Loop line OUT (+)
3	Loop line IN (-)
4	Loop line OUT (-)
5	Not used
6	Not used
7	Common 1
8	Common 2
9	Normally open 1
10	Normally open 2
11	Normally closed 1
12	Normally closed 2

The 50002 single channel relay output mini-module provides pole changeover contacts for the control of auxiliary devices such as fire shutters.

GENERAL OVERVIEW - 50110 INPUT/OUTPUT SUPERVISED MINI-MODULE

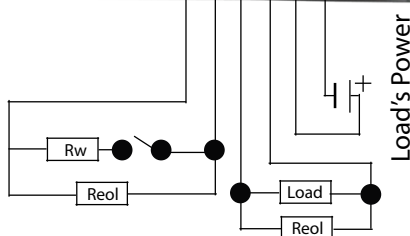

Terminal	Description
1	Loop line IN (+)
2	Loop line OUT (+)
3	Loop line IN (-)
4	Loop line OUT (-)
5	Input (+)
6	Input (-)
7	Load (+)
8	Load (-)
9	Load power (+)
10	Load power (-)
11	Not used
12	Not used

The 50110 input and output supervised DIN rail module combine in a single device supervised input and output characteristics.

End of line resistor (Reol):27 Kohm. - Alarm resistor (Rw):10 Kohm.

GENERAL OVERVIEW - 50102 INPUT/OUTPUT FREE CONTACTS MINI-MODULE

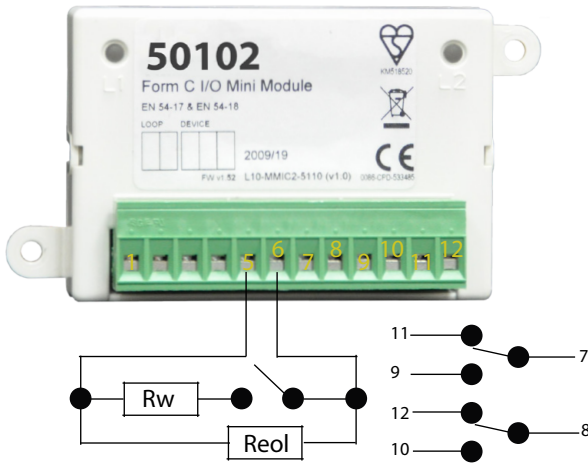

Terminal		Description
1	Loop line IN (+)	Loop positive input
2	Loop line OUT (+)	Loop positive output
3	Loop line IN (-)	Loop negative input
4	Loop line OUT (-)	Loop negative output
5	Input (+)	Supervised input (+)
6	Input (-)	Supervised input (-)
7	Common 1	Relay contact terminal
8	Common 2	Relay contact terminal
9	Normally open 1	Relay contact terminal
10	Normally open 2	Relay contact terminal
11	Normally closed 1	Relay contact terminal
12	Normally closed 2	Relay contact terminal

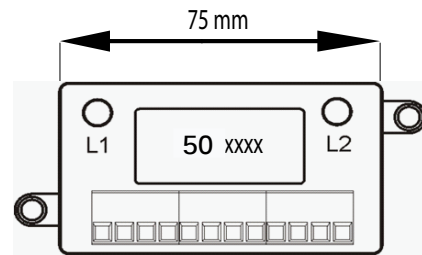
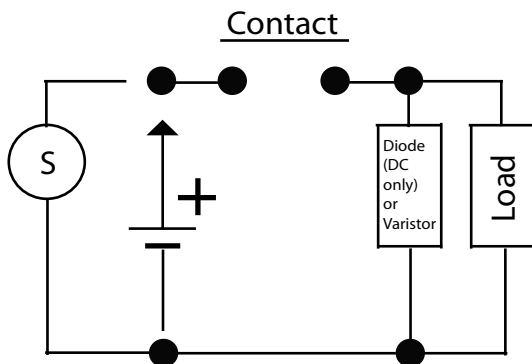

When switching an inductive load, in order to protect the mini-module from surges caused by counter-EMF, it is important to protect the relay contacts. A diode with a reverse breakdown voltage of at least ten times the circuit voltage (DC applications only) or a varistor (AC or DC applications) should be connected in parallel to the load.

TECHNICAL SPECIFICATIONS

Specification	50100	50010	50002	50110	50102
Standard	EN54- 18 / 17				
Fault Protection	In - built Isolator				
Connection on the loop	Loop Powered				
No of Devices per loop	As per load calculator				
Power supply	15-40VDC				
Aver Current Consumption	I-120µA (@24VDC)				
LED's Current Consumption	6mA (@24VDC)				
Operating Temp	- 30°C to +70°C				
Dimensions	75x52x28mm				
Weight	180grams				
Max wire gage	2.5mm				
Ingress Protection	IP21C or higher when mounted in weather boxes				
Supervised Input	1	-	-	1	1
Supervised Output	-	1	-	1	-
Un - supervised output	-	-	2	-	2