

VELOX 40000 Series

Intelligent Detectors With Isolators



Features

- LPCB approved to EN54-7 and EN54-5 A1R
- High reliability communication protocol
- In-built isolator in each device
- Automatic Addressing
- Manual Addressing via the 40700 programmer
- 240 devices up to 2Km per loop
- Inbuilt diagnostics, hardware and software drift Compensation
- 360° visible Bicolor (Red/Green) LED driven by Control Panel
- Independent Remote Output
- Magnetic Test features

Decentralized intelligence, while centralized reporting

The new VELOX intelligent detectors are delivered with a unique technology addressing both decentralized and centralized intelligence. The detectors are equipped with the latest microprocessor with inbuilt sophisticated fire algorithms to detect different fire criteria patterns. Each detector is equipped with Intelligence for drift compensation, short circuit detection and isolation, automatic and manual addressing and much more.

The intelligent detector as well communicates back to the fire alarm control panel transmitting all detector parameters such as operating conditions, fault signals, as well as all the smoke obscuration levels and the exact temperature measurements via the sophisticated Variable Time Communication "VTC" protocol allowing further centralized analysis from the fire alarm control panel.

Cost effective installation is added benefit

Subject to the loop load calculations, 240 devices can be connected on the VELOX 2Km loop length using 1.5mm² cable, were all the devices are powered from the same loop. This exceptional feature shall drop the cost dramatically, and make the installation task faster and easier task to achieve.

Zero downtime

Each detector is supplied with in-built short circuit isolator, in case of a single fault; no device shall be lost on the loop. This shall only provide higher reliability to the performance as well as easy installation to comply with the latest standards and regulations.

Five years Warranty

The VELOX clients enjoy 5 years warranty on all the ATEIS devices, thanks to the Double Dust Trap "DDT" patented technology. This technology protects the smoke chamber from the dust effects, as the dust is trapped in special trays outside the chamber. This shall extend the life span of service for each detector, reduce unwanted faults, and provide peace of mind when choosing the VELOX technology.

Adaptive Drift Compensation

The sophisticated algorithms inside each detector, provides decentralized intelligence to compensate the obscuration measurements in case of dust and other similar contaminants inside the chamber. The "ADC" technology keeps the detection threshold window uniform with fixed detection sensitivity, unlike other drift compensation methods in the market that reduces the detection threshold window allowing a change in sensitivity.

* Special module is required, please contact your authorized dealer.

ATEIS Middle East FZCO.

LIU No.11 Dubai Silicon Oasis
P.O. Box 293640 Dubai United Arab Emirates.
Tel. +971 (4) 3262730 - Fax. +971 (4) 3262731
info@ateis.ae, www.ateis.ae, www.velox.ae

Variable Time Communication Digital Protocol

With VELOX "VTC" communication technology, the communication is guaranteed in the most difficult communication environments, allowing the information packets to travel across only a two core cable up to 2Km..The VELOX 4000 series fire alarm control panels not only identify the earth location on the loop, but also the type of earth leakage, whether it be on the positive or negative conductor.

Commissioning is never easier

ATEIS wants to make it easy to the installer, no dip or rotary switches are required to address the detectors nor barcode scanners or other difficult methods of installation are needed. Automatic addressing is an added benefit to the many others of VELOX technology, were the fire alarm control panel addresses each device in a sequential manner, and make sure that no duplicate addresses are allowed. Furthermore when needed to assign an address in a non-sequential fashion, the manual programming via the VELOX detector programming tool is utilized.

VELOX magnetic test simulates the action of an alarm in the detector to drive the cause & effect and test the detector's functions when testing an installation.

Uniform first fix

ATEIS strives to make the installation an easy task. The Uniform First Fix or "UFF" makes all the detectors interchangeable on the same base type. Not only that, sounder bases, flashers and much more shall be installed on the same type of base, allowing the VELOX detectors to share the same type of base, permitting ease install and swap feature. Furthermore, single centrally positioned LED allows detector identification an easy task.

Various options of detection technology

The VELOX intelligent smoke detectors operates on the

light scattering principle, which makes the detector an excellent choice for smoldering fires "thanks to the advanced algorithms in built on each detector head."

The combination of Smoke Scattering with the centralized low inertia thermistor makes the Velox detector the best choice as a general detector to most types of fires, smoldering and fast burning fires.

The detector is equipped with 10 sensitivity levels allowing the detector to operate according to user desire. The VELOX intelligent heat detectors operates on the centrally positioned thermal thermistor principle, which makes the detector an excellent choice to detect high energy emitting fires as well as low energy heat emitting fires that gradually increases with time, thanks for the advanced algorithms embedded in the detector head as well as the approved two sensitivity levels A1R which is Rate of Rise Detection of 58C° as well as the Class B which is High Temperature of up to 78C°.

Physical construction and assembly

The VELOX range of products is constructed from a high impact, elegant ABS white enclosure, and the patented

360° symmetrical smoke chamber allows the smoke to easily enter the chamber from all the directions. The chamber is complete with a patented Double Dust Trap "DDT" that protects the chamber from airborne contaminants thus reducing the problem of false alarms.

The detector is supplied with a continuous screen, where protecting the smoke chamber from small insects.

Approvals & compliance with standards

The entire VELOX systems confirm to BS 5839 part 1 and EN54 standards. The entire range of VELOX intelligent detectors are LPCB listed to EN54 standard part 7 and 5. This only means enhanced reliability and precision performance.

General Overview

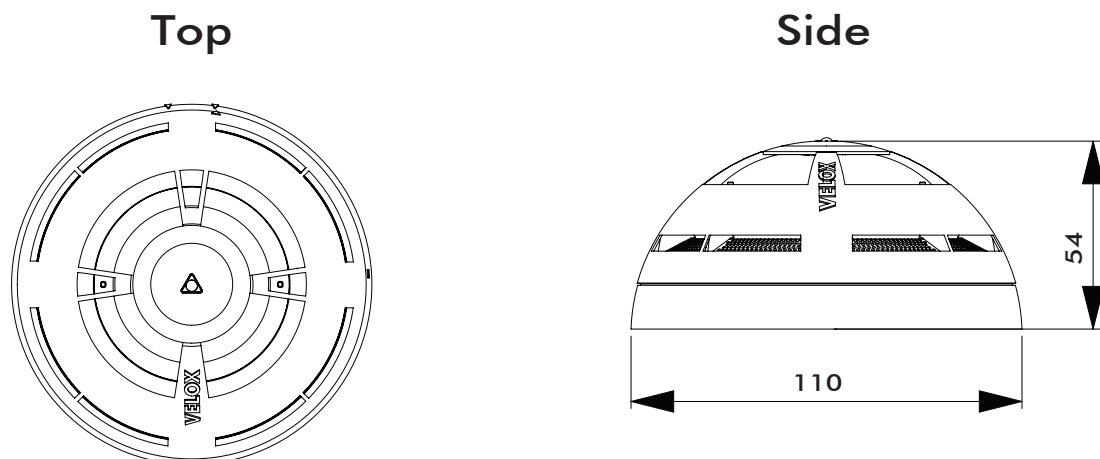

Technical Specifications

Item	Specification Details		
	40910	40920	40930
Standard	EN54 Part 7	EN54 Part 7	EN54 Part 5
Sensitivity	4 levels	10 levels	3 levels
Approval	LPCB		
Protocol	Advanced Variable Time Communication (VTC)		
Loop Connection	240 devices up to 2Km *		
Dimension (mm)	110x54		
Storage Temperature	-30C° to 70C°		
Operating Temperature	-30C° to 70C°		
Operating Humidity	95% RH (non-condensing)		
Ingress Protection	IP30 estimated on flat ceiling IP45 estimated with optional gasket		
Air Flow	10m/s gusting for up to 30 minutes 5m/s continuous		
Vibration	5-6011z		
Color	RAL 9016 as standards Decorative Colors on demand optional		
LED	Bicolor (Red/Green) visible at 500Lux ambient light at 3m installed height From Finished Floor Level		
Average Current consumption	I=70 uA		
Power Supply	15-40 V		
Output driver current	6mA @24Vdc		
LED current consumption	6mA @24Vdc		
Weight	110g		
Mode of operation	Wired connection		

Order Codes

Part No.	Description
40910	Intelligent analogue addressable optical detector
40920	Intelligent analogue addressable optical & heat detector
40930	Intelligent analogue addressable heat detector
40900	VELOX adaptor base
40900-DP	VELOX deep adaptor base
40900-S	VELOX adaptor base with short clip
40900-DPS	VELOX deep adaptor base with short clip
40200	4 tones intelligent addressable loop power sounder base

* Note 1. Subject to load calculations and correct cable selection

As our policy is one of constant product improvement the right is therefore reserved to modify product specifications without prior notice
Ref. 40000 Series/D/R1/V2/061013

ATEIS Middle East FZCO.

LIU No.11 Dubai Silicon Oasis
P.O. Box 293640 Dubai United Arab Emirates.
Tel. +971 (4) 3262730 - Fax. +971 (4) 3262731
info@ateis.ae, www.ateis.ae, www.velox.ae